

# HIGHLANDER

MUSICAL AUDIO PRODUCTS

## Pro Acoustic Mix DI

Two Channel • Extended Range • Four Band Tunable EQ

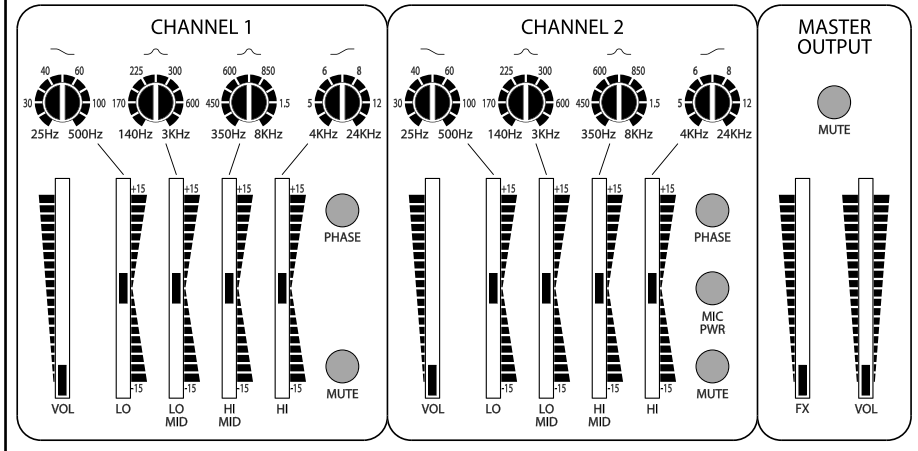

# Owner's Manual

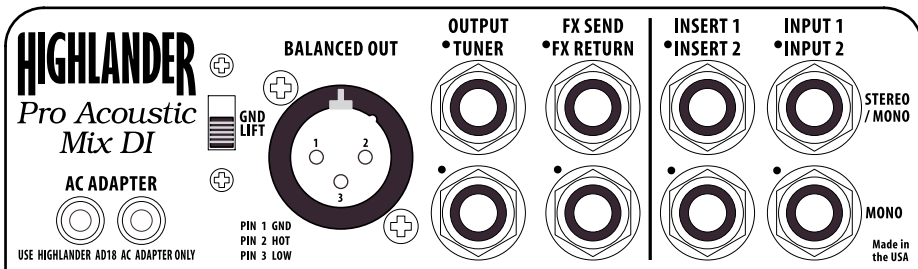

*The Pro Acoustic Mix DI*  
*An Acoustic Powerhouse*

## *Welcome*

Welcome to the Highlander Pro Acoustic Mix DI and thank you for placing your trust in Highlander Products.

The Pro Acoustic Mix DI offers a level of audio quality and versatility that until now could only be obtained by purchasing bulky, "rack mount" equipment. What's more, the Pro Acoustic Mix DI is small enough to fit in the accessory compartment of many guitar cases and can be powered by batteries, making it completely portable (120 hours from two 9V batteries).

The Pro Acoustic Mix DI includes a Two Channel Mixer with Four Band Tunable EQ on each Channel, Phase Reverse Switching, Mic Power, Effects Loop, Integrated DI (XLR, balanced output) and much more. The Ultra-Low Noise, Extended Range Electronics deliver the ultimate in warmth and clarity. Ergonomically engineered to provide unsurpassed ease of use, this is truly an Acoustic Powerhouse.

Taking a little time to familiarize yourself with the workings of the Pro Acoustic Mix DI will help you gain the maximum benefit from this powerful tool.

Best wishes from the staff at Highlander.

YOU CAN RELY ON A  
**HIGHLANDER**

870 CAPITOLIO WAY, UNIT 3 · SAN LUIS OBISPO, CA 93401 USA

TEL: 805.547.1410 · FAX: 805.547.1228

U.S. & CANADA TOLL FREE: 888.658.1819

EMAIL: [hmap@highlanderpickups.com](mailto:hmap@highlanderpickups.com)

WEBSITE: [highlanderpickups.com](http://highlanderpickups.com)

---

# Important Information

## **Retain this Manual:**

The operating instructions should be read before the unit is operated.

## **Water and Moisture:**

The unit should not be used near water (e.g. near a sink, etc.) or exposed to rain, sleet or snow. Care should be taken so that liquids are not spilled into the enclosure.

## **Mechanical:**

Do not expose the unit to excessive vibration including loudspeakers. Care should be taken so that objects do not fall on the unit. The unit should not be dropped. Avoid situations where any cables attached to the unit could cause someone to trip and hurt themselves or cause the unit to fall.

## **Heat:**

The unit should not be situated in direct sunlight and should be kept away from heat sources such as radiators, stoves or other appliances including amplifiers that produce heat.

## **Grounding:**

The unit is grounded by the audio equipment it is plugged into. Make sure that the audio equipment that the unit is plugged into is properly grounded.

## **Power Source:**

The unit should be connected to a power supply only of the type described in the operating instructions or as marked on the unit and its AC Adapter. Do not stand on the power cable.

## **Cleaning:**

The unit should be cleaned using a slightly damp (almost dry) soft cloth. Do not use cleaning or polishing products. Do not spray the unit with water or any liquid cleaners.

## **Non-Use Periods:**

The AC Power Adapter should be unplugged from the outlet, and the batteries should be removed when the unit is not going to be used for long periods of time.

## **Servicing:**

The user should not attempt to service the unit beyond what is described in the operating instructions. All servicing should be referred to qualified personnel.

# Contents

<b>Quick Start .....</b>	<b>6</b>
Power and Connections .....	6
Basic Settings .....	7
<b>Front Panel Controls .....</b>	<b>8</b>
<b>Back Panel Connectors .....</b>	<b>10</b>
<b>Input Channels in Detail .....</b>	<b>12</b>
Recommended Types of Pickups .....	12
Instrument Microphones .....	12
Channel Volume Controls .....	12
Channel Inserts .....	12
Phase Reverse .....	13
The EQ .....	13
Extended Range EQ .....	14
Tunable EQ .....	14
Using Tunable EQ .....	15
Artistic Use of EQ .....	15
Using EQ to deal with problems .....	15
<b>Pitch to Frequency Table .....</b>	<b>16</b>
Examples of Pitch to Frequency conversion .....	16
<b>Master Output in Detail .....</b>	<b>17</b>
Output Level .....	17
Master Mute .....	17
Tuner Output .....	17
The FX Loop (Special Effects) .....	18
Unbalanced Output .....	18
Balanced Output .....	18
Ground Lift Switch .....	18
Unbalanced and Balanced Connections .....	19
Unbalanced Connections .....	19
Balanced Connections .....	19
<b>Power .....</b>	<b>20</b>
AC Adapter .....	20
Using Batteries .....	20
Installing Batteries .....	20
LED Power Indicator and Battery Level Monitor .....	20
<b>Block Diagram .....</b>	<b>22</b>
<b>Tech Specs .....</b>	<b>23</b>
Extended Response .....	23

---

# Quick Start

## Power and Connections

Plug in the AD18 AC Adapter (into any one of the two AC Adapter connectors) or install two 9V Batteries and turn on the Pro Acoustic Mix DI. The LED should come on. If batteries are being used, the LED will start slowly flashing. This is normal, it saves battery power. **When the batteries need to be changed the LED will flash quickly.**

Remember to mute or turn down the console and/or amplifier before plugging in any cables.

Plug in instrument or instruments (two max). If Instrument 1 has two pickups or a pickup and mic, use a stereo cable and do not plug in a second instrument. If a stereo cable is being used, the pickup that is wired to the tip will be connected to Channel 1.

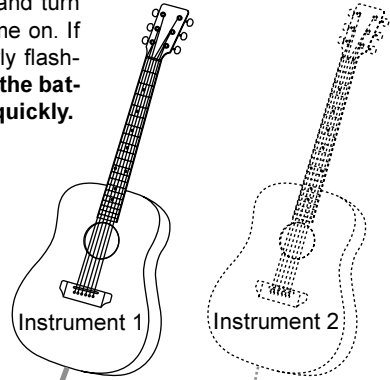

Stereo/Mono  
Guitar Cable

Guitar Cable

AC Adapter

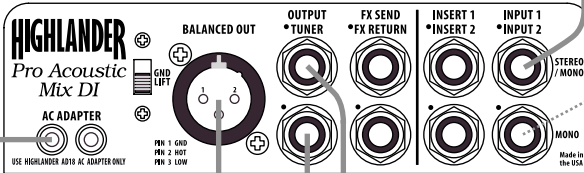

XLR (Balanced) Cable  
30 feet to 250 feet long

PA or Recording Console

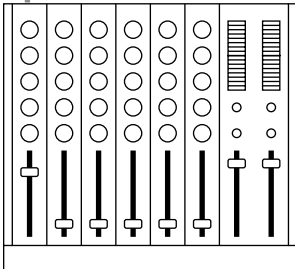

Guitar Cable

Guitar Cable

Tuner

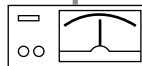

Acoustic Instrument  
Amplifier

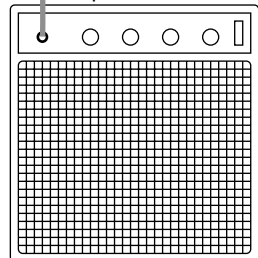

## Basic Settings

Connect Instrument Mics that require power to Channel 2. The "MIC PWR" button should be DOWN to turn on Mic Power. Highlander's Internal Mic does Not Require Mic Power.

**The Master Mute:** Mutes the signal from both outputs but leaves the tuner signal on.

**The Channel Mutes:** Mutes the channel and the tuner signal.

**Phase:** Both phase buttons should be in the UP position (not phase reversed).

**A) DOWN**  
(Power ON).

**C) UP** (not muted).

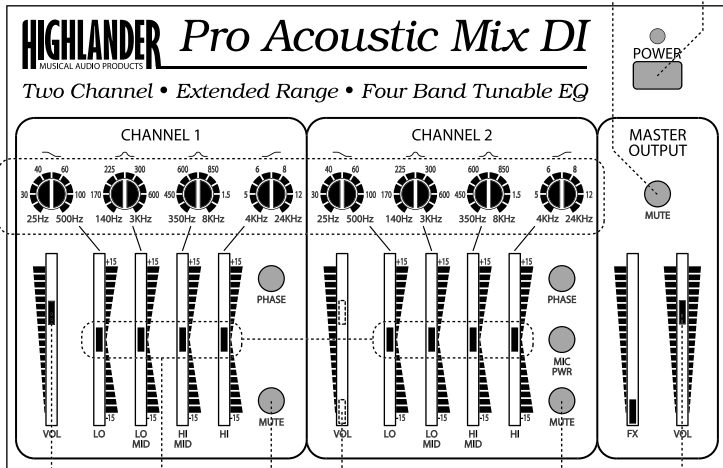

**F) Move Channel 1**  
Volume up to this  
position.

**G) For a second pickup or**  
instrument bring up  
Channel 2 Volume.

**H) Bring Master**  
Volume up  
slowly until the  
instrument is  
loud enough.

**D) UP** (not muted).

These knobs have no effect until the EQ faders are moved up or down from center.

**B) Set all 8 EQ faders to the center (detent) position. In this position the EQ is bypassed.**

**E) UP** for two pickups, pickup and mic or two instruments. **DOWN** for one instrument.

# Front Panel Controls

The controls for both Input Channels are identical with the exception of Mic Power on Channel 2, therefore, only one set of controls is detailed.

Use Channel 2 with either a pickup or an Electret (Instrument) Microphone. Mic Power on Channel 2 is NOT REQUIRED for Highlander's Internal Mic.

The EQ will be explained in detail in the chapter on Using Tunable EQ.

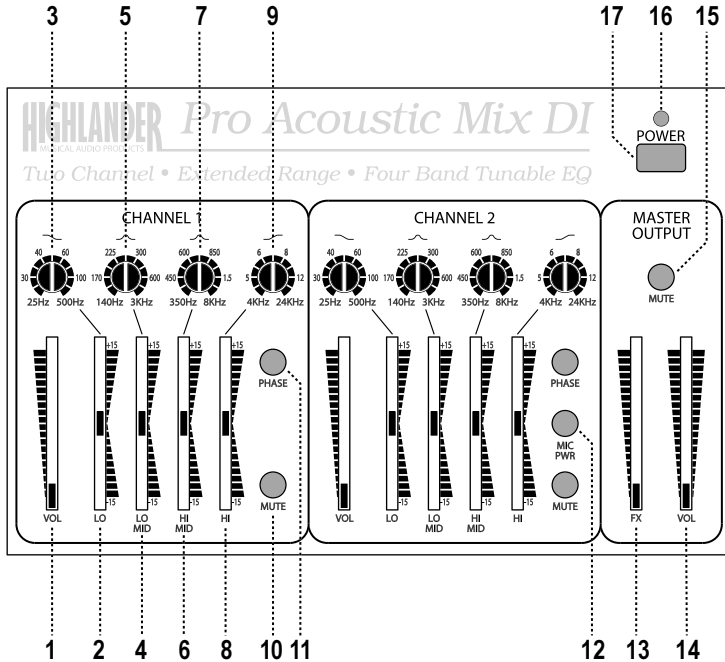

- 1) Channel Volume:** Controls the loudness of each channel. Typically set between half way and all the way up, depending on how loud the source (pickup) is.
  - For an instrument with two pickups or a pickup and a microphone like our IP-2 and Internal Mic, the Channel Volume controls can be used to adjust the balance between both sound sources.
  - In situations where two instruments are connected (one to each channel), the volume of each instrument can be adjusted independently.

- 2) **LO (Bass) Boost/Cut:** Center position is off (no EQ). See page 13 “The EQ”.
- 3) **Tune (sweep) the LO Pitch:** Typically set at 40Hz for acoustic guitar.
- 4) **LO Mid Boost/Cut:** Center position is off (no EQ). See page 13 “The EQ”.
- 5) **Tune (sweep) the LO Mid Pitch:** See “Using Tunable EQ” on page 15 for settings.
- 6) **HI Mid Boost/Cut:** Center position is off (no EQ). See page 13 “The EQ”.
- 7) **Tune (sweep) the HI Mid Pitch:** See “Using Tunable EQ” on page 15 for settings.
- 8) **HI (Treble) Boost/Cut:** Center position is off (no EQ). See page 13 “The EQ”.
- 9) **Tune (sweep) the HI Pitch:** For acoustic guitar set between 12KHz to 24KHz
- 10) **Channel Mute:** Turns the sound from the channel off including the output to the tuner.
  - Note: The Master Mute mutes the output but leaves the tuner on. If two instruments are being used, and one is being tuned, the other instrument can be muted to avoid “leakage” into the tuner.
- 11) **Channel Phase:** Phase reverse can be used to correct for two pickups (or a pickup and a microphone) that are out of phase with each other. When two pickups are out of phase, the sound from the instrument will get thinner (less bass) as the two pickups are mixed. Reversing the phase of one of the two pickups will correct this situation. Generally, the pickup that is considered to be secondary has its phase reversed. In some instances switching the phase can reduce or eliminate feedback. See page 13 “Phase Reverse”.
- 12) **Mic Power on Channel 2 only:** Used to power Electret Condenser (Instrument) Mics.
  - Not Required for Highlander’s Internal Mic
- 13) **Master FX:** Controls the loudness of a special effect (e.g. reverb) that is connected to the effects loop.
- 14) **Master Volume:** Controls the overall loudness. Set between half way and all the way up.
  - When setting up, first bring the Channel Volume  $\frac{3}{4}$  (75%) of the way up. Bring the Master Volume up slowly until a suitable level is obtained. If the Master Volume is all the way up and there is not enough level, bring up the Channel Volume.
- 15) **Master Mute:** Turns off the signal coming from both the  $\frac{1}{4}$ ” output jack and the XLR (Balance Out) while leaving the signal from the Tuner Output on, so an instrument can be tuned up without audience participation.
- 16) **LED Power Indicator:**
  - When using the AC Adapter, this LED is on continuously when the unit is On.
  - When using batteries, this LED will come on for a few seconds then start to flash approximately once every 3 seconds. This saves battery power.
  - Batteries should last for approximately 120 hours (that’s 60, two-hour gigs). The LED will start flashing faster (once a second) when the batteries need changing.
- 17) **Power Switch:** This turns the unit On and Off. Always make sure the amplifier or PA that the “Pro Acoustic Mix DI” is connected to is muted or turned down before turning the power On or Off.

# Back Panel Connectors

When connecting to either the ¼" Output Jack or the XLR Balanced Out, make sure the amplifier or PA you are connecting to is turned all the way down or muted.

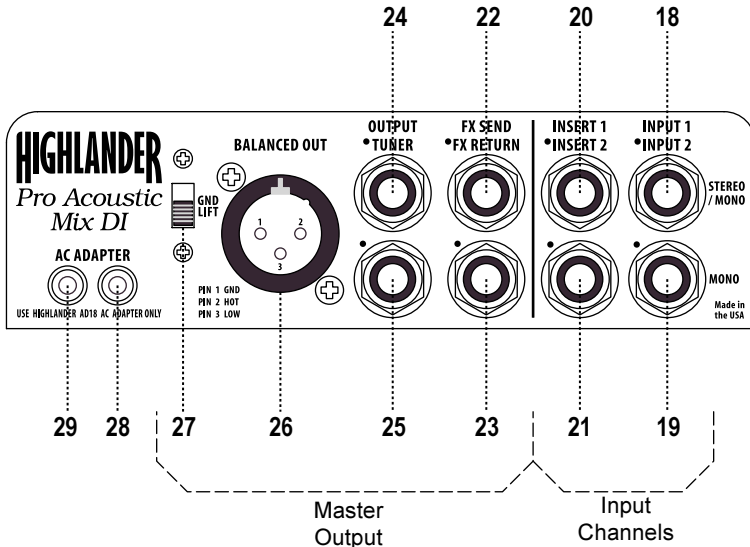

- 18) **Channel 1 Input Jack:** This is a stereo ¼" jack that can be used in two ways.
  - Stereo: An instrument with 2 pickups or a pickup and mic that are wired to a stereo output jack can connect both pickups to both Input Channels using a stereo cable. The Tip connects to Channel 1. The Ring connects to Channel 2.
  - Mono: An instrument with one pickup can be connected using a regular (mono) guitar cable.
- 19) **Channel 2 Input Jack:** This is a mono ¼" jack for connecting to Channel 2.
  - Use this input when using two instruments that each have a single pickup. One instrument is plugged into Channel 1, the other into Channel 2.
  - Or to use Channel 2 instead of Channel 1.
- 20) **Channel 1 Insert:** Enables an effect to be inserted into Channel 1. This is a stereo ¼" jack; Send is on the Tip, and Return is on the Ring. A stereo to 2 mono insert cable is available from Highlander.
- 21) **Channel 2 Insert:** Enables an effect to be inserted into Channel 2. This is a stereo ¼" jack; Send is on the Tip, and Return is on the Ring. A stereo to 2 mono insert cable is available from Highlander.

- 22) **Master FX Send:** ¼" mono jack for connecting to the input of an effects unit such as reverb.
- 23) **Master FX Return:** ¼" mono jack for connecting to the output of the effects unit.
- 24) **Master Unbalanced Output:** ¼" mono jack for connecting to the unbalanced input on equipment such as an acoustic instrument amplifier, certain power amplifiers or powered speakers.
- 25) **Tuner Output:** Connect to the input of a tuner. The Tuner Output stays on when the Master Mute is active. The Tuner Output is muted by either of the Channel Mutes.
- 26) **Master Balanced Output (DI):** A 3-pin XLR connector for connecting to a PA, recording console, certain power amplifiers or powered speakers.
- 27) **Ground Lift Switch:** Disconnects the ground connection to the XLR (Balanced Out) connector. Used to prevent "hum" caused by ground loops. Use the switch in whichever position provides the quietest connection.
  - UP is ground lifted.
  - DOWN is grounded. Default position is down. Always try this position first.
- 28) **AC Power Adapter Input:** (see 29)
- 29) **AC Power Adapter Input: Do Not Plug In 2 AC Adapters Simultaneously. The batteries are disconnected when the AD18 AC Adapter is plugged in.**
  - Either connector (28) or connector (29) can be used to plug in the AD18 AC Adapter. There are two connectors making it possible to power more than one Pro Acoustic Mix DI from a single AD18 AC Adapter using a Power Jumper Cable available from Highlander.
  - Use Highlander's AD18 AC Power Adapter Only.
  - Contact Highlander to purchase alternate AC Adapters for countries that use voltages other than 120VAC.

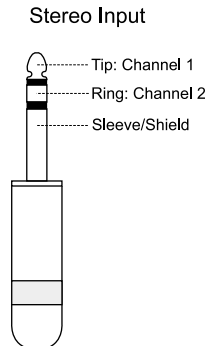

# Input Channels in Detail

## Recommended Types of Pickups

The Pro Acoustic Mix DI is designed to give optimal audio performance when used with “Active” or low impedance pickups.

- Active pickups have a “matching preamplifier” and require power, typically a 9V battery.
- Low impedance pickups are normally magnetic sound hole pickups.

High impedance pickups such as “piezo pickups” without a “matching preamplifier” are not recommended. These pickups may work but will probably sound thin. The low noise and low distortion inherent in the Pro Acoustic Mix DI will not be fully realized.

## Instrument Microphones

There are a wide variety of Electret Condenser Microphones available for acoustic instrument amplification. Unfortunately, there is no “standard” method for powering these mics. The Pro Acoustic Mix DI has a unique and innovative microphone power circuit (see page 8, control 12) on Channel 2. This circuit senses the power requirements of almost every (two wire) type of Electret Mic available and delivers optimal power for each type of microphone.

- When running from batteries, battery life will be reduced when using a powered mic. This varies according to the power requirements of the mic.
- Mic Power is not intended for Studio Type Condenser Microphones like the AKG 414, etc.
- Mic Power is Not Required for Highlander’s Internal Mic.

## Channel Volume Controls

A fader (1) on each channel. There are two basic uses for these controls:

- When an instrument is equipped with two pickups or a pickup and microphone (such as Highlander’s IP-2), these two controls can be used for balancing the sound from both sources.
- When using two instruments (each with a single pickup), the volume of each instrument can be set to the appropriate level. If a solo musician is using both instruments, the levels can be left in the appropriate positions, and the Channel Mutes can be used to select a particular instrument.

The optimum position for these controls depends on the type of instrument, pickup and playing style.

**Tip:** If the Master Volume has to be kept below half way, try turning down the Input Channels until the Master Volume is at least half way up.

## Channel Inserts

Connectors (see page 10, connectors 20 & 21) are used to insert an effect into each channel. Bass Players sometimes use Channel Inserts to insert a compressor. The main difference between a “Channel Insert” and an “Effects Loop” is that when using a Channel Insert, the entire signal is passed through the (inserted) effect (which may compromise the audio quality), whereas with an Effects Loop, the effect is mixed with the original signal, therefore, there is no risk of degrading the original signal’s audio integrity.

- Both insert jacks are stereo. Send is on the Tip. Return is on the Ring. A “stereo to 2 mono cable” is required to connect to an effect unit. The Tip is connected to the effect’s input, the Ring is connected to the effect’s output (see diagram).
- It is possible to use the Channel Insert as a direct output from each channel. A cable is required that has a stereo plug on one end and a mono plug on the other end. The stereo plug has the Tip and Ring connected together and wired to the Hot of that cable. The mono plug is wired as normal (see diagram).

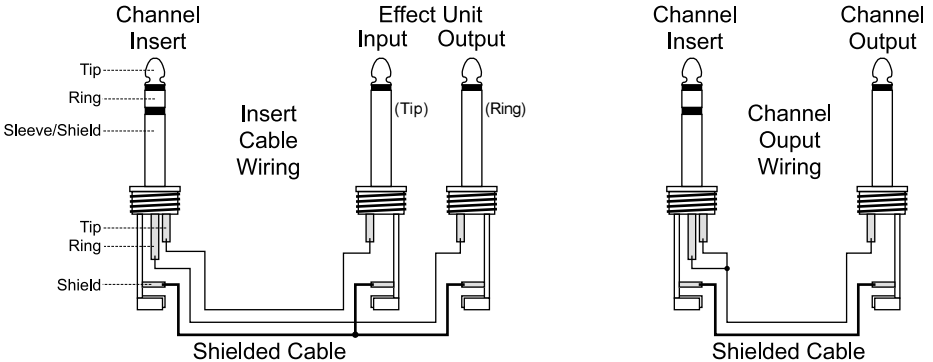

### Phase Reverse

A push button (11) that reverses the phase of the signal when pushed. Phase Reverse can be used to correct for two pickups (or a pickup and a microphone) that are out of phase with each other. This can happen if the pickups or mics have been purchased from different manufacturers or modified by a previous owner. When two pickups are out of phase, the sound from the instrument will get thinner (less bass and less volume) as the two pickups are mixed. Reversing the phase of one of the two pickups will correct this situation. Generally the phase is switched on the pickup that is considered to be secondary. In some instances switching the phase can reduce or eliminate feedback. If two pickups are being used the phase of both have to be switched to determine if there is any effect on feedback.

### The EQ

Each channel’s EQ has four sections LO, LO MID, HI MID and HI. Each section has two controls: a fader (or slider) (2,4,6,8) for boosting and cutting and a (rotary) knob (3,5,7,9) for tuning (selecting pitch). When a fader is in the center (neutral) position, that section of the EQ has no effect on the sound. The center position has a detent or click that positively identifies the neutral position. Pushing the fader up from center “boosts” and pulling down from center “cuts”.

When using any EQ, in order to achieve the lowest levels of noise and distortion, it is better to “cut” than to “boost”.

In order to discuss EQ, it necessary to understand that what engineers call frequency and musicians call pitch actually refer to the same thing. Musicians refer to a pitch as a note, for example, “A” whereas engineers refer to a frequency in cycles per second for example 440Hz (1Hertz or 1Hz is one cycle per second). Many musicians are familiar with “A 440” where “A” refers to a musical note and 440 refers to 440Hz. Engineers use “KHz” (kilohertz) as a kind of shorthand for a thousand cycles per second. (See the “Pitch to Frequency Table” on page 16).

### Extended Range EQ

Unlike many other equalizers the range of frequencies on the Pro Acoustic Mix DI extends down to 25Hz in the bass end and up to 24KHz in the treble end. There is a good reason for this.

- At the bass end, 82.4Hz is the frequency of the “low E” string on a guitar in open tuning at concert pitch. Many EQ’s have their bass frequency preset around 80Hz. If 80Hz is boosted, the “low E” string is actually getting louder and the string balance suffers. By setting the bass frequency between 25Hz – 40Hz, the bass harmonics are boosted, warming up the sound, while maintaining string balance even if the guitar is in “drop D” or “C” tuning. Being able to boost or cut 25Hz is especially useful for bass instruments.
- Tech Note: The Input Channel; low end is rolled-off at 15Hz using a phase linear filter to avoid boosting subsonic frequencies when the EQ is set to 25Hz.
- At the treble end many EQ’s are preset between 10KHz – 12KHz. Boosting these pitches can result in a harsh, edgy sound. By boosting 24KHz, the high end sounds open and airy without any harshness. Although the human ear cannot hear 24KHz, we are sensitive to harmonics that are accentuated by boosting this frequency. This is a subtle but very musically pleasing effect that has been used by some of the world’s top recording engineers for many years.

### Tunable EQ

Tuning the EQ means that it is possible to select which pitch to boost or cut as opposed to having the pitch preset by the manufacturer of the EQ. This flexibility enables a musician to tune the EQ to produce exactly the desired effect or compensation. Because it is impossible to select just one pitch, the user should be aware that pitches close to the one that is selected will also be affected but to a lesser degree than the “center” or “selected” pitch.

There are two types of tunable EQ available on the Pro Acoustic Mix DI:

- Shelving EQ: The “LO” and “HI” sections of the EQ are called shelving filters.
  - ~ For the LO (bass) end that means that the pitch that is selected and every pitch below it are affected.
  - ~ For the HI (treble) end the selected pitch and every pitch above it are affected.
- Notch EQ: The “LO MID” and “HI MID” sections of the EQ are called notch filters. This means that the selected pitch is affected more than the pitches that are just above and below the selected pitch.

The terms “Shelving” and “Notch” are derived from looking at a graph used by sound engineers that has pitch from bass to treble along the horizontal axis and loudness on the vertical axis. If you plot the response of these types of EQ on such a graph, one looks like a “shelve” and the other looks like a “notch”.



## Using Tunable EQ

EQ is basically used in two ways. One use is artistic, enhancing the sound of an instrument or modifying the sound of the instrument to better suit a piece of music. The other reason for using EQ is to deal with problems, compensating for a bad sounding room or instrument or for dealing with feedback in a room that has less than ideal acoustics.

**The most important tool when using EQ is the ear of the user.**

## Artistic Use of EQ

The most common use of EQ is to boost or cut the bass or treble. As discussed above, there are ways to do this with extended range EQ that are subtle and musical. With tunable EQ it is possible to experiment. For example, let's say a bass boost is required. Move fader (2) up from center until the effect is heard then try rotating the EQ tuning knob (3) until the desired sound is achieved. The same holds true for a treble boost or cut using fader (8) and knob (9). Both mid range sections of the EQ can have very interesting effects and the user is encouraged to experiment, just remember that when experimenting, boosting can cause feedback. Practice at low volume can save ears and speakers.

## Using EQ to deal with problems

Feedback is the most common problem that EQ is used to deal with. Several factors are involved in inducing feedback: the shape and size of the room, the materials the room and stage are made of, speaker placement and the loudness or volume of the PA. Before deciding to use EQ to solve a feedback problem, here are few tips on some of these other factors:

- Small rooms are more likely to induce feedback than large ones. Keep the volume down in small rooms.
- If possible cover reflective surfaces like a tiled floor with a rug, if there are windows in the room close the curtains. If temperature, outside noise and neighbors are of no concern, then open the windows.
- Place the main PA speakers at either end of the stage, well in front of the performers, just above the heads of the audience and pointed straight ahead. Experiment with speaker placement, sometimes moving a speaker a few feet to the left or right can have a profound effect on feedback, especially in odd-shaped rooms. If monitor speakers are used, then point them at the side of the instrument, not the top or back.
- If the stage is “boomy”, place any speakers or instrument amplifiers that are on the stage up on a stand or chair. If possible cover the stage with a rug.
- As long as the people in the back of the room can hear the performance, use the lowest volume possible.

If all else fails, it is time to resort to EQ. This is where the “LO MID and HI MID” sections of the EQ come into play.

- The performer should be in position on stage with their instrument connected to the Pro Acoustic Mix DI, (which should be connected to the PA).
- With Channel Volume (1) down, bring up the Master Volume (14) to about  $\frac{3}{4}$  of its travel.
- Bring up the Channel Volume (1) slowly until the onset of feedback then back off slowly until the feedback stops.

- If the pitch of the feedback is low, then bring up the “LO MID” fader (4) a little and rotate the tuning knob (5) until the onset of feedback. By rotating the tuning knob, the pitch of the feedback is determined.
- Pull fader (4) below center to reduce feedback and bring up the Channel Volume. It should now be possible to raise the Channel Volume higher than before. As the Channel Volume is raised, EQ fader (4) may have to be brought down some more. Listen to the sound of the instrument while pulling EQ fader (4) down. Too much “cut” can cause the sound of the instrument to suffer.
- If a different pitch starts to feedback, follow the same procedure as above with the appropriate EQ section.

## Pitch to Frequency Table

The following table may be helpful when using Tunable EQ:

PITCH	OCTAVE									
	0	1	2	3	4	5	6	7	8	9
					MIDDLE C					
C	16.4	32.7	65.4	130.8	<b>261.6</b>	523.3	1046.5	2093.0	4186.0	8372.0
C#, Db	17.3	34.6	69.3	138.6	277.2	554.4	1108.7	2217.5	4434.9	8869.8
D	18.4	36.7	73.4	146.8	293.7	587.3	1174.1	2349.3	4698.6	9397.3
D#, Eb	19.4	38.9	77.8	155.6	311.1	622.3	1244.5	2489.0	4978.0	9956.1
E	20.6	41.2	82.4	164.8	329.6	659.3	1318.5	2637.0	5274.0	10548.1
F	21.8	43.7	87.3	174.6	349.2	698.5	1396.9	2793.8	5587.6	11175.3
F#, Gb	23.1	46.2	92.5	185.0	370.0	740.0	1480.0	2960.0	5919.9	11839.8
G	24.4	49.0	98.0	196.0	392.0	784.0	1568.0	3136.0	6271.9	12543.8
G#, Ab	26.0	51.9	103.8	207.7	415.3	830.6	1661.2	3322.4	6644.9	13289.7
A	27.5	55.0	110.0	220.0	<b>440.0</b>	880.0	1760.0	3520.0	7040.0	14080.0
A#, Bb	29.1	58.3	116.5	233.1	466.2	932.3	1964.7	3729.3	7458.6	14917.2
B	30.9	61.7	123.5	246.9	493.9	987.8	1975.5	3951.1	7902.1	15804.3

FREQUENCY IN HERTZ (CYCLES PER SECOND)

### Examples of Pitch to Frequency conversion

Double Bass in Open Tuning

E = 41.2Hz  
A = 55Hz  
D = 73.4Hz  
G = 98Hz

Guitar in Open Tuning

E = 82.4Hz  
A = 110Hz  
D = 146.8Hz  
G = 196Hz  
B = 246.9Hz  
E = 329.6Hz

Mandolin in Open Tuning

G = 196Hz  
D = 293.7Hz  
A = 440Hz  
E = 659.3Hz

# Master Output in Detail

The MASTER OUTPUT is the section of the Pro Acoustic Mix DI where both Input Channels are combined (electronically mixed). The Master Output Fader (14) drives both the Unbalanced (24) and Balanced (26) outputs. The MASTER section provides an input for the FX return and an overall mute.

## Output Level

The level (loudness) from the Master Output is controlled by fader (14) marked VOL. Generally this control should be set between half way to three quarters of the way up. In some instances, especially when driving a professional power amplifier and speakers, it may be necessary to set this control all the way up. Instrument Amplifiers and PA systems typically require less level than professional power amplifiers, although each time the Pro Acoustic Mix DI is used with a new system, the optimum operating levels should be carefully determined. When determining the optimum level, it is important to test the system by playing the loudest parts of the performance while paying particular attention to any “meters” or “clipping lights” on consoles or amplifiers that are connected to the Pro Acoustic Mix DI. It is undesirable and potentially damaging to overdrive equipment. A little experimentation in order to obtain the optimum, cleanest sound is in the best interest of the user, the audience and the equipment.

When initially setting up:

- Bring the Master Fader (14) all the way down.
- Move the appropriate Channel Volume faders (1) to approximately  $\frac{3}{4}$  way up.
- Move the Master Fader (14) up a little and play, check the level and repeat until the desired volume is attained.

If the Master Fader (14) is less than  $\frac{1}{2}$  way up and the sound is loud enough, either:

- Bring down the volume of the Instrument Amp, Power Amp, PA or recording console that the Pro Acoustic Mix DI is connected to
- Or bring down the Channel faders on the Pro Acoustic Mix DI

Then bring up the Master Fader until it is at least half way up.

## Master Mute

When in the “down position” this button (15) mutes (turns off) both the Balanced (26) and Unbalanced (24) outputs, however, it does not mute the output to the tuner (25) (see Tuner Output).

## Tuner Output

Use this  $\frac{1}{4}$ ” jack (25) to connect the Pro Acoustic Mix DI to a tuner.

The Channel Mutes and the Master Mute have different effects on the tuner output:

- The Channel Mutes mute the tuner.
- The Master Mute does not mute the tuner.

The Master Mute enables instruments to be discretely tuned up (without the audience hearing). By using the Channel Mutes, a musician who has two instruments plugged in can tune either instrument while muting the other to prevent it from “leaking” into the tuner and causing false readings.

## **The FX Loop (Special Effects)**

The “FX Loop” is a combination of an output or FX Send, an input or FX Return and FX Fader that enables the user to mix a special effect (e.g. reverb or echo) with the sound of the instrument. A portion of the signal from both Channels is combined (electronically mixed) and connected to the FX Send Jack. The amount of signal from each Channel is determined by the level of each Channel’s Fader (1). The FX Return is connected to the FX Fader, which in turn is routed to the Master Output Mixing Stage.

Note: The FX Return can be also be used as an extra instrument input, although there is no EQ, Phase Reverse or separate Mute.

Connecting the Pro Acoustic Mix DI to a special effects unit:

- The FX Send (22) is connected to the input of an effects unit.
- The FX Return (23) is connected to the output of the effects unit.
- The FX Fader (13) is used to adjust the desired loudness of the effect.

When using the FX loop, it is important that the special effect unit in question only passes the “wet”, or effect signal and does not include any of the “dry” or original signal.

## **Unbalanced Output**

Output Jack (24) is for connecting to equipment that has unbalanced (mono) inputs, e.g. Instrument Amplifiers. There are some Power Amplifiers and Powered Speakers that may also be equipped with unbalanced inputs. This output may be used to connect to a console if it is in close proximity (within 25 feet) to the Pro Acoustic Mix DI and has unbalanced line inputs.

## **Balanced Output**

Output Jack (25) and the Ground Lift Switch (27) alleviate the need for a “DI Box” when playing live on stage or in any situation where there is a considerable distance (more than 20 - 30 feet) between the Pro Acoustic Mix DI and the piece of equipment it is being connected to.

## **Ground Lift Switch**

Use the GND LIFT switch (27) to prevent ground loops (see Unbalanced verses Balanced Connections on page 19) that can cause a low frequency hum. It does this by disconnecting ground from the XLR connector. Use whichever switch position results in the cleanest sound with the least hum.

- UP is Ground Lifted
- DOWN is grounded. This is the default position. Always try this position first.

Note: Because the Pro Acoustic Mix DI does not obtain a ground connection from the AC outlet, ground loops are more likely to occur when both outputs (24 and 26) are connected to different pieces of equipment.

## **Unbalanced and Balanced Connections**

The following definitions may help to clarify the discussion on unbalanced and balanced connections.

- Shield in an audio cable is a series of thin, uninsulated wires that are wrapped or braided around the “hot” wire to prevent electromagnetic interference from imposing noise on the audio signal.
- Electromagnetic interference radiates from many sources including: Light Dimmers, Computers, Radio, Cell Phones, TV, AC Wiring, Fluorescent Lighting, Electric Motors and even sun spot activity.

For the purpose of this discussion the main difference between an unbalanced and a balanced signal is:

- One “hot” wire and shield are used to transmit the unbalanced signal. Shield is a necessary part of signal transmission and is connected to ground to shield the signal from unwanted interference.
- Two wires are used to transmit a balanced signal. The shield is connected to ground in order to protect the signal from interference but is not a necessary part of signal transmission.

**There are pros and cons to both of these strategies:**

### **Unbalanced Connections**

- Unbalanced connections in general are more accurate, especially where very high pitches and/or fast, percussive signals are concerned. Percussive signals refer to the “spike” or “transient” that is created, for example, when a guitar string is struck by a pick.
- Typical unbalanced cables are less expensive.
- Unbalanced signals are more prone to (electromagnetic) interference when cables longer than 20 - 30 feet have to be used.
- When using a PA where the PA Console and the stage gear may be plugged into different AC outlets, a phenomenon known as a ground loop can cause unacceptable levels of low frequency hum. Because an unbalanced signal uses grounded shield as a necessary part of signal transmission, ground loops cannot easily be overcome.

### **Balanced Connections**

- Balanced connections are almost impervious to (electromagnetic) interference and can be used over distances of a hundred feet or more.
- Because balanced connections do not use ground as a necessary part of signal transmission, ground loops are easily overcome. All that is required to prevent a ground loop is to disconnect or lift ground at one end of the balanced cable. This can be accomplished in the Pro Acoustic Mix DI by the use of the GND LIFT Switch (27).
- Typical balanced cables are more expensive.
- Systems using balanced connections do so out of practical necessity, although under certain circumstances there is no substitute for a balanced connection. The unbalanced connection has the potential for better audio fidelity.

# Power

The Pro Acoustic Mix DI is turned on using the Power Button (17). When the Power Button is down, the unit is on.

Power can be supplied in one of two ways:

- By using the AD18 AC Adapter
- By installing two standard 9V batteries

When the AD18 AC Adapter is plugged in, the batteries are automatically disconnected.

## AC Adapter

The AD18 AC Adapter is designed to operate several Pro Acoustic Mix DI's (and/or equipment that Highlander may produce in the future). Therefore, there are two AC Adapter Sockets (28 & 29). Either socket can be used to plug in the AD18. The other socket can be used with the optional AC Jumper Cable to "daisy chain" several units to one AD18. The AD18 supplies AC voltage which is converted to DC in the unit.

Important: Do Not Plug 2 AC Adapters.

## Using Batteries

Use two standard 9V batteries. Alkaline batteries are preferred, they provide long life and stable, low noise operation. Battery life is approximately 120 hours (that's 60, two-hour gigs), although this can vary depending on the type of batteries used and how old they are when purchased. Also, the use of Instrument Microphones that require power from the Pro Acoustic Mix DI will reduce battery life.

Please dispose of all batteries in an environmentally responsible manner. Check with your local recycling center for information on the correct procedure for "used battery" disposal.

## Installing Batteries

Fig 1 - Fig 4 indicate how to open the battery compartment. Once it is open, remove the old batteries (if any) and disconnect them. Connect two new batteries and install them in the battery compartment.

Avoid pulling hard on the battery wires.

Note: While changing batteries, it is OK to place the Pro Acoustic Mix DI upside down on a flat surface. The controls are protected.

## LED Power Indicator and Battery Level Monitor

The Red LED (16) lights when the Pro Acoustic Mix DI is turned on. This LED has three modes of operation.

- When using the AD18 AC Adapter, the LED will stay on continuously.
- When operating from batteries, the LED will flash slowly at a rate of approximately one flash every 3 seconds.
- When operating from batteries that are low on power, the LED will start to flash faster, at a rate of approximately one flash per second. When this first happens, the batteries are still usable but should be changed within four hours. This enables the user to finish playing a gig, but the batteries should be replaced before the next gig.

To obtain the maximum battery life, it is important to check that the unit is turned off when not in use especially before it is stored for any length of time. Always make sure that any equipment that the Pro Acoustic Mix DI is plugged into is muted or turned down before the unit is turned ON or OFF.

There are several reasons why the LED may not light when the unit is turned on.

- If the unit is operating from batteries, the batteries may have run down. Change the Batteries.
- The battery connectors may not be properly connected to the batteries.
- If an AD18 is plugged into the unit, the AC power to the AD18 may not be on.
- If an AD18 is plugged in, make sure the plug is all the way in.

If the LED does not come on and these possibilities have been eliminated, then contact the dealer where the unit was purchased or Highlander for advice and or service.

**Hold the unit upside down with thumbs on the rubber pads.  
Use thumbs to slide the battery compartment door.**

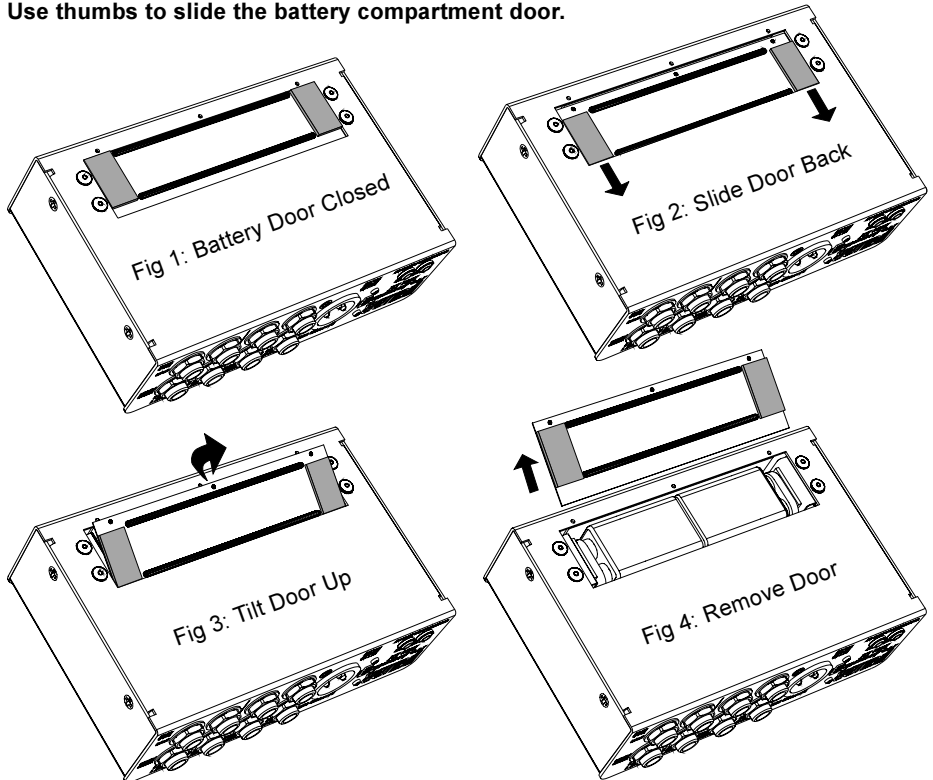

# Block Diagram

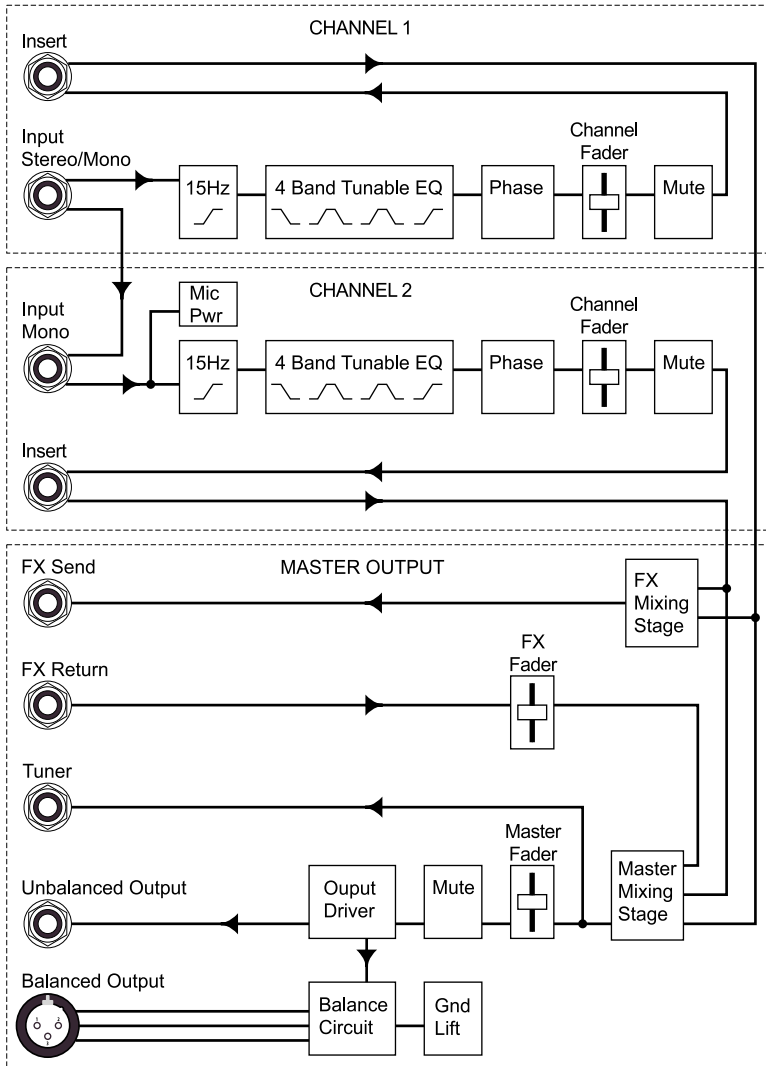

# Tech Specs

## Recommended Types of Pickups:

All types of Active Pickups, Passive Magnetic Pickups, Electret (Instrument Microphones)  
Input Impedance: 700K

## System (Input through to Output)

With the exception of "Clipping" all of the following specifications apply to either method of powering the unit (Batteries or AC Adapter).

Frequency Response:	±0.5dB 15Hz to 200KHz
	±3dB 10Hz to 400KHz
Slew Rate:	5V/μS
THD: (1KHz @ 0dB)	0.01% (*Predominantly 2nd Harmonic)
2nd Harmonic Distortion	0.009%
3rd Harmonic Distortion	0.001%
Noise:	-98dB
Clipping Level (Battery Power):	17.3dB (115.3dB Dynamic Range)
Clipping Level (AC Adapter):	19.5dB (117.5dB Dynamic Range)
Input Sensitivity:	-12dB (Typical for acoustic instrument pickups)

## Equalization

LO: tunable shelving	25Hz - 500Hz	±15dB
LO MID: tunable notch	140Hz - 3KHz	±15dB
HI MID: tunable notch	350Hz - 8KHz	±15dB
HI: tunable shelving	4KHz - 24KHz	±15dB

## Power

Power Requirements: ±9VDC to ±12VDC @ 4.2mA  
The AD18 AC Adapter supplies AC voltage, which is converted to DC in the unit.

\* 2nd Harmonic distortion, at the low levels that it occurs in the Pro Acoustic Mix DI, is probably not audible. However, this type of harmonic distortion is the prevalent type of distortion in tube amplifiers and is associated with warm sound.

## Extended Response

During the course Highlander's extensive research, harmonics as high as 45KHz have been regularly measured emanating from acoustic guitars. We are sure that many acoustic instruments produce even higher harmonics. While the human ear cannot detect frequencies this high, these harmonics do have an effect on what we hear and perceive. For example, it is well known that two frequencies that are close in pitch generate "beat" frequencies. Some musicians use these beat frequencies to aid in tuning. These beat frequencies are actually the sum and difference of the original pitches. If the difference between two high harmonics (e.g. 40KHz and 42KHz) is 2KHz, this can be heard even though the harmonics cannot.

Typically, in order to "roll off" the low end, a phase shift is incurred. Our Extended Low End Response insures that bass instruments will not suffer any phase shift when their lowest notes are played through Highlander equipment.

These are just some of the reasons why Highlander strives to produce equipment with Extended Frequency Response.

## Limited Warranty

HIGHLANDER MUSICAL AUDIO PRODUCTS (herein referred to as HIGHLANDER) warrants its products shall be free from defects in materials and workmanship under normal use for a period of one year commencing on the consumer's date of purchase. This warranty does not apply to asserted defects caused by modifications, misuse or abuse.

LIMITATIONS ON OBLIGATION: The obligation of HIGHLANDER hereunder is limited to repair or replacement of parts for its product found to be defective under this Limited Warranty. In no event shall HIGHLANDER be liable for any indirect, incidental or consequential damages, including but not limited to lost profits, of any nature or kind, or for damages to persons or property whether such liability claim is based on breach of warranty or contract, negligence or any other legal duty or obligation.

In the event of a product defect during the warranty period, contact HIGHLANDER directly. HIGHLANDER will, at its option, unless otherwise provided by law: (a) correct the defect by product repair without charge for parts and labor; (b) replace the product with one of the same or similar design. All replaced parts and products become the property of HIGHLANDER. Repaired or replaced parts and products are warranted for the remainder of the original warranty period. You will be charged for repair or replacement of the product made after the expiration of the warranty period.

This warranty does not cover: (a) damage or failure caused by or attributed to acts of God, abuse, accident, misuse, improper or abnormal usage, failure to follow instructions, improper installation or maintenance, alteration, lightning or other incidence of excess voltage or current; (b) any repairs other than those provided by HIGHLANDER; (c) consumables such as batteries; (d) cosmetic damage; (e) transportation, shipping or insurance costs; or (f) costs of product removal, installation, set-up service adjustment or reinstallation.

This warranty gives you specific legal rights, and you may also have other rights which vary from state to state.



870 CAPITOLIO WAY, UNIT 3 · SAN LUIS OBISPO, CA 93401 USA

TEL: 805.547.1410 · FAX: 805.547.1228

U.S. & CANADA TOLL FREE: 888.658.1819

EMAIL: [hmap@highlanderpickups.com](mailto:hmap@highlanderpickups.com)

WEBSITE: [highlanderpickups.com](http://highlanderpickups.com)